



ESR



Bowl elevator-tipper

ESR bowl elevators-tippers are used to transfer the dough from ISE/A - ISE N A - FBLA - SPI A mixer bowls with removable trolley onto a worktable or a hopper assembled on SP - DVP volumetric dividers.

Standard features

- Sturdy steel structural frame painted with epoxy powder-coating (suitable for food contact).
- Stainless steel dough chute.
- Hydraulic ram lifting system.
- "Hold-to-run" type control panel.
- 24V low-voltage electric control panel.
- Power supply: 400V/3/50Hz (different voltage upon request).



MODELS

ESR / 4	Bowl elevator-tipper - Version for tipping from the bottom onto a worktable.
ESR / 4M	Bowl elevator-tipper - Version for tipping from the top onto a hopper.



SOLLEVATORE - ROVESCIAIORE DI VASCHE

NOR06F0_01

BOWL ELEVATOR

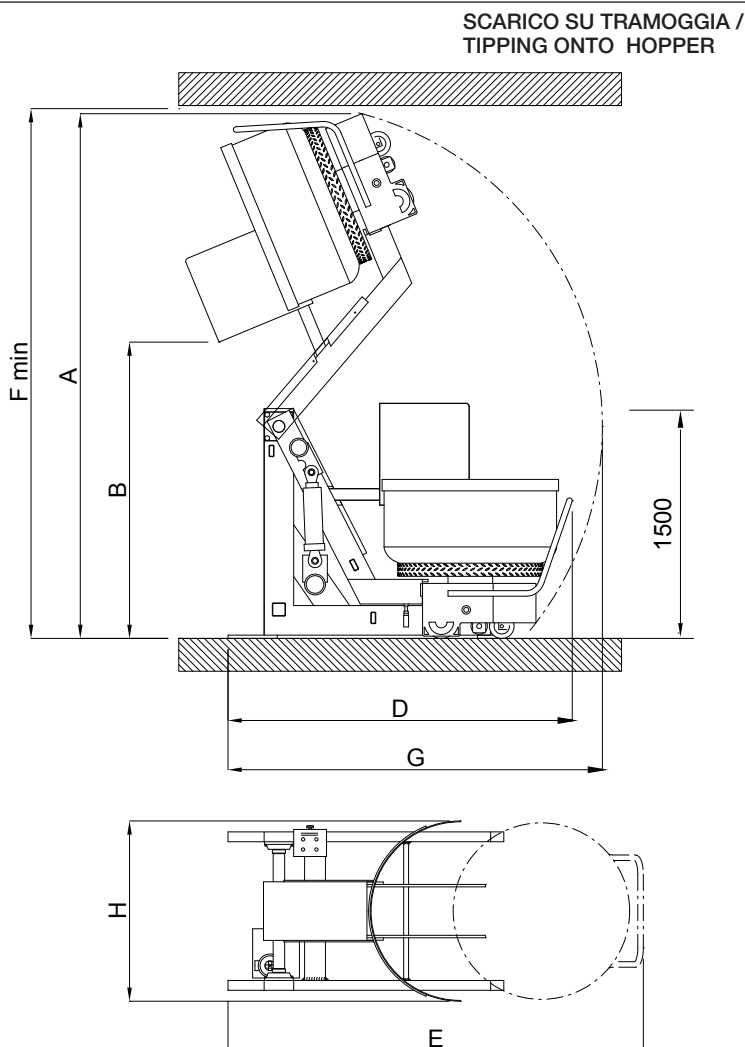
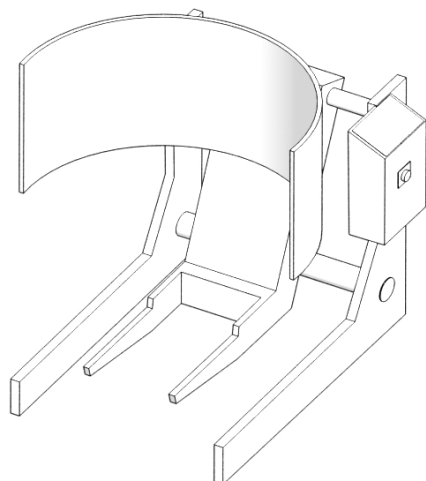

Properties of Esmach SpA - reproduction prohibited

SOLLEVATORE - ROVESCIAIORE DI VASCHE / BOWL ELEVATOR

DATI TECNICI / TECHNICAL FEATURES		CARRELLO / TROLLEY ISE NA - SPI A		CARRELLO / TROLLEY ISE A	
		160-200	250-300	160-200	250-300
A	mm	3200	3200	3260	3325
B	mm	1880	1810	1931	1750
C	mm	275	275	332	335
D	mm	1989	2100	1989	2055
E	mm	2530	2530	2350	2405
F	mm	3230	3230	3310	3375
G	mm	2285	2285	2278	2355
H	mm	940	1090	940	1090
POTENZA INSTALLATA / INSTALLED POWER		kW	1,2	1,2	1,2
POTENZA MAX ASSORBITA / MAX ABSORBED POWER		kW	1,2	1,2	1,2
PESO / WEIGHT		kg	360	370	370
VOLUME IMBALLO / PACKING VOLUME		m3	3,2	3,4	3,4
CONNESSIONE ELETTRICA / PLUG COUPLING			3PH+Gr	3PH+Gr	3PH+Gr



Properties of Esmach SpA - reproduction prohibited

SOLLEVATORE - ROVESCIAIORE DI VASCHE

NOR06F0_02

BOWL ELEVATOR

SCARICO SU BANCO /
TIPPING ONTO WORKTABLE

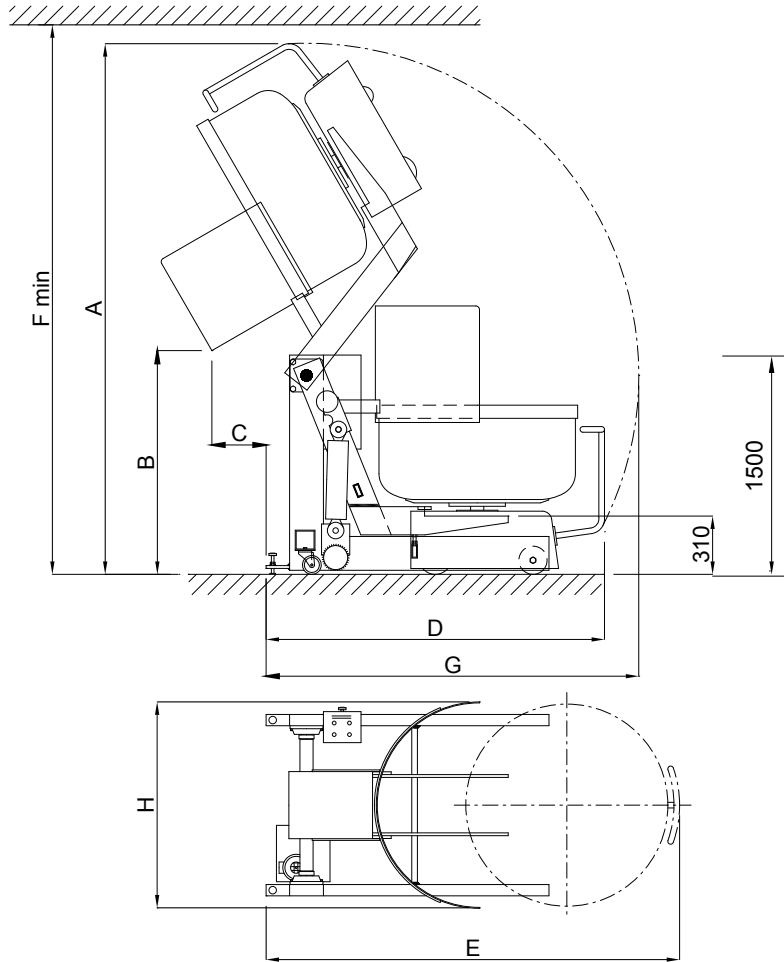
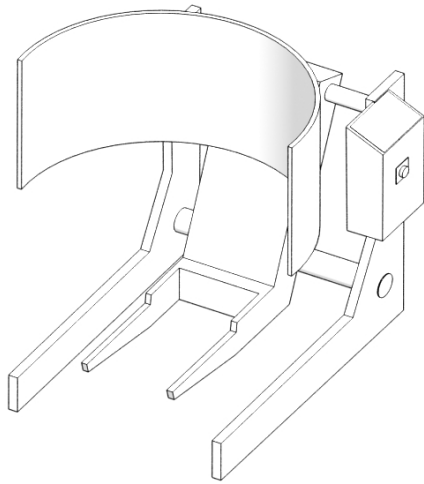

SOLLEVATORE - ROVESCIAIORE DI VASCHE / BOWL ELEVATOR

DATI TECNICI / TECHNICAL FEATURES		CARRELLO / TROLLEY ISE NA - SPI A		CARRELLO / TROLLEY ISE A	
		160-200	250-300	160-200	250-300
A	mm	2690	2690	2730	2800
B	mm	1270	1200	1275	1200
C	mm	315	315	265	265
D	mm	1750	1750	1680	1750
E	mm	220	2200	2140	2200
F	mm	2740	2740	2780	2850
G	mm	1835	1835	1880	1950
H	mm	940	1090	940	1090
POTENZA INSTALLATA / INSTALLED POWER	kW	1,2	1,2	1,2	1,2
POTENZA MAX ASSORBITA / MAX ABSORBED POWER	kW	1,2	1,2	1,2	1,2
PESO / WEIGHT	kg	340	350	340	350
VOLUME IMBALLO / PACKING VOLUME	m3	3,2	3,4	3,2	3,4
CONNESSIONE ELETTRICA / PLUG COUPLING		3PH+Gr	3PH+Gr	3PH+Gr	3PH+Gr