



# E-PLANET



## Bench planetary mixer

E-PLANET is a new generation table-top planetary mixer created to tackle moderate daily productions in small environments, which represents the evolution of the well-known Saturne 3 range. It can be placed on top of a work bench or on a dedicated stand. Thanks to the proven technology of the dough produced by Esmach, the planetary mixer model E-Planet and its interchangeable tools can be used to process creams, sauces and mayonnaise, mixes and doughs of different density and consistency (even some bread dough) in addition to doughs for delicatessen products. The design and its smooth surfaces allow a quick, simple and accurate cleaning.

### Standard features

- Steel structure, top cover in shockproof thermoformed ABS.
- Paint finish with epoxy powders (suitable for contact with food). Alternatively, stainless steel structure.
- Stainless steel bowl and flour protection device
- Robust, accurate and silent construction.
- Simple, quick and safe bowl hooking with locking levers.
- The tools are easy to assemble/disassemble even when the bowl is already fitted.
- Table-top machine.
- Machine equipped with three fixed feet and an adjustable rear levelling foot to adapt the machine to the supporting floor.
- Lid: transparent plastic bowl cover suitable for contact with food in compliance with the strictest hygiene and safety standards. Washable lid with opening for adding ingredients.
- Quick and intuitive tool connection.
- Standard tools: stainless steel hook, stainless steel wire whisk, stainless steel spatula.

### VRV



E-Planet is proposed in the continuously variable speed version, electronic control, manual working mode.

### TOOLS

Stainless steel hook



Stainless steel whip



Stainless steel flat beater





E-PLANET

E-PLANET

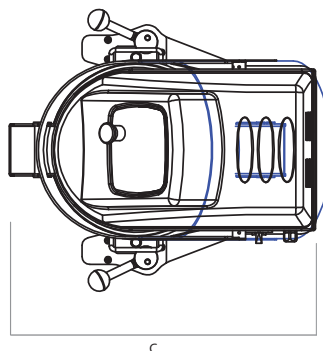
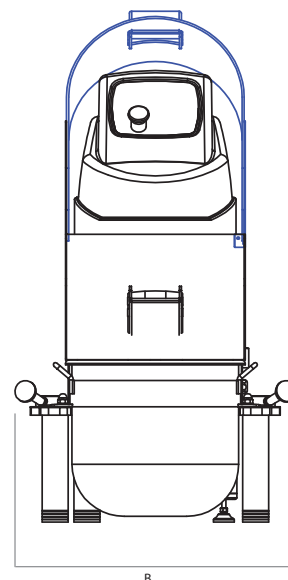
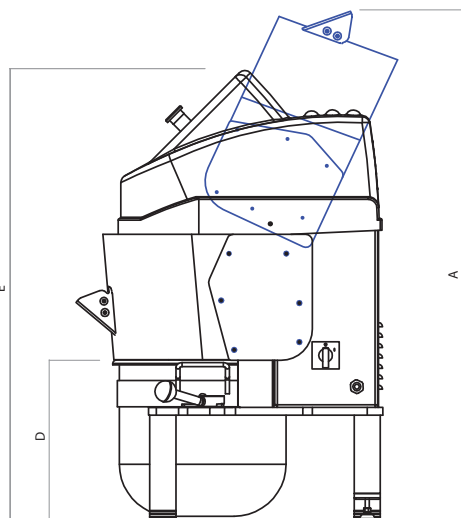
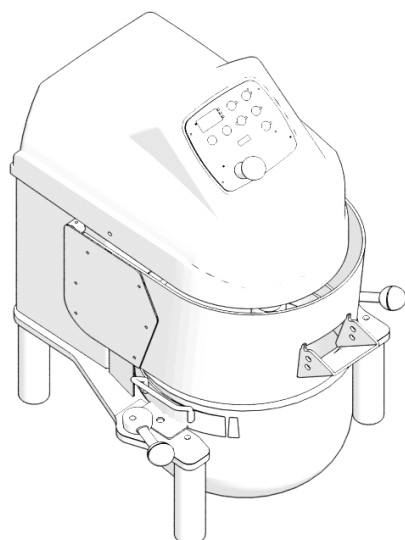

Dati tecnici/Technical features		E-PLANET VRV	
A	mm	981	
B	mm	541	
C	mm	579	
D	mm	311	
E	mm	867	
Capacità vasca/Bowl capacity	l	20	
Dimensioni vasca/Bowl dimensions:			
• diametro/diameter	mm	320	
• altezza/height	mm	300	
Potenza installata/Installed power	kW	1,1	
Potenza max assorbita/Max. absorbed power	Kw	1,1	
Connessione elettrica/Plug coupling		3PH+Gr	
Massa/Weight	kg	100	
P.S.: E' necessario installare un interruttore differenziale / NOTE: It is necessary to install a circuit-breaker.			