



# SFN



## Standard and Deluxe Dough Sheeter

### Standard features

- Painted steel structural frame on casters and thermoformed ABS cover.
- Synthetic and polyurethane-coated conveyor belts.
- Stainless steel trays for dough collection and painted conveyor belt support frames.
- Laminating cylinders with 84 mm Ø and adjustable opening ranging from 0,2 up to 50 mm.
- Ergonomic, precise and thickness-adjustable handle of new generation with graduated double toothing scale. For "Deluxe" version the value set is shown on display.
- Easily removable polyethylene scrapers.
- Rolling-pin holder supports on both surface extremities, rolling-pins included as a standard supply.

- Conveyor belt working surfaces foldable upwards once production has ended in order to contain machine surface area.
- Reversal of conveyor belt direction with double controls, i.e. manual and through pedals.

### Configurations

- Standard version, speed of delivery conveyor belt : 60 cm/sec
- Deluxe version, variable speed of delivery conveyor belt ranging from 12 up to 60 cm/sec, electronically adjustable and visualization of set thickness shown on display.

IMPORTANT NOTE: No cutting-roller supplied as a standard.

### MODELS

SFN50-75 std	Dough sheeter with conveyor belt dimensions: 500 x 750 mm. Cylinder Ø : 84 mm.
	Cylinder opening: 0,2-55 mm. Speed of delivery conveyor belt : 60 cm/sec.
SFN50-75 luxe	Dough sheeter with conveyor belt dimensions: 500 x 750 mm. Cylinder Ø : 84 mm.
	Cylinder opening: 0,2-55 mm. Speed of delivery conveyor belt : 12-60 cm/sec.
SFN50-100 std	Dough sheeter with conveyor belt dimensions: 500 x 1000 mm. Cylinder Ø : 84 mm.
	Cylinder opening: 0,2-55 mm. Speed of delivery conveyor belt : 60 cm/sec.
SFN50-100 luxe	Dough sheeter with conveyor belt dimensions: 500 x 1000 mm. Cylinder Ø : 84 mm.
	Cylinder opening: 0,2-55 mm. Speed of delivery conveyor belt : 12-60 cm/sec.
SFN50-120 std	Dough sheeter with conveyor belt dimensions: 500 x 1200 mm. Cylinder Ø : 84 mm.
	Cylinder opening: 0,2-55 mm. Speed of delivery conveyor belt : 60 cm/sec.
SFN50-120 luxe	Dough sheeter with conveyor belt dimensions: 500 x 1200 mm. Cylinder Ø : 84 mm.
	Cylinder opening: 0,2-55 mm. Speed of delivery conveyor belt : 12-60 cm/sec.
SFN60-100 std	Dough sheeter with conveyor belt dimensions: 600 x 1000 mm. Cylinder Ø : 84 mm.
	Cylinder opening: 0,2-55 mm. Speed of delivery conveyor belt : 60 cm/sec.
SFN60-100 luxe	Dough sheeter with conveyor belt dimensions: 600 x 1000 mm. Cylinder Ø : 84 mm.
	Cylinder opening: 0,2-55 mm. Speed of delivery conveyor belt : 12-60 cm/sec.



**MODELS**

SFN60-120 std	Dough sheeter with conveyor belt dimensions: 600 x 1200 mm. Cylinder Ø : 84 mm.
	Cylinder opening: 0,2-55 mm. Speed of delivery conveyor belt : 60 cm/sec.
SFN60-120 luxe	Dough sheeter with conveyor belt dimensions: 600 x 1200 mm. Cylinder Ø : 84 mm.
	Cylinder opening: 0,2-55 mm. Speed of delivery conveyor belt : 12-60 cm/sec.
SFN60-140 std	Dough sheeter with conveyor belt dimensions: 600 x 1400 mm. Cylinder Ø : 84 mm.
	Cylinder opening: 0,2-55 mm. Speed of delivery conveyor belt : 60 cm/sec.
SFN60-140 luxe	Dough sheeter with conveyor belt dimensions: 600 x 1400 mm. Cylinder Ø : 84 mm.
	Cylinder opening: 0,2-55 mm. Speed of delivery conveyor belt : 12-60 cm/sec.
SFN60-160 std	Dough sheeter with conveyor belt dimensions: 600 x 1600 mm. Cylinder Ø : 84 mm.
	Cylinder opening: 0,2-55 mm. Speed of delivery conveyor belt : 60 cm/sec.
SFN60-160 luxe	Dough sheeter with conveyor belt dimensions: 600 x 1600 mm. Cylinder Ø : 84 mm.
	Cylinder opening: 0,2-55 mm. Speed of delivery conveyor belt : 12-60 cm/sec.

**Options**

- Stainless steel structural frame.
- DRT - Device for application of cutting-rollers (rollers not included ) (for SFN 60 140-160 "Deluxe" version only). For new machines departing from the factory.
- Cutting-rollers complete with discs and T/C-triangular,
- T/RO-round, T/RC-round with smooth and toothed edge, T/O-oval, T/Q-squared, T/RE - rectangular-shaped cutting figures

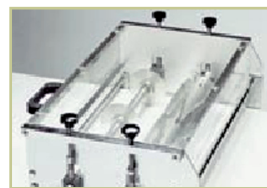

Cutting device



Interchangeable rollers

**ESEMPI RULLI DI TAGLIO: TRIANGOLO (CROISSANT) /EXAMPLES OF CUTTING-ROLLERS: TRIANGLE - SHAPED (CROISSANT)**

Base x altezza/ Base x Height mm	Peso crudo/Raw weight g	N° tranci/No. of pieces
130x170	50-80	3
70x85	14-20	6
70x102	17-23	5
80x102	20-27	5
90x127	28-35	4
110x127	35-45	4
100x170	40-55	3
150x170	60-90	3
170x170	70-100	3

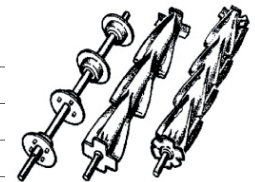

**ESEMPI RULLI DI TAGLIO: TONDO E OVALE/ EXAMPLES OF CUTTING-ROLLERS: ROUND AND OVAL**

Diametro/Diameter mm	Peso crudo/Raw weight g	N° tranci/No. of pieces
100	30-50	5
60	Dec-20	9
80	22-30	7
120	50-70	5
140	65-85	4
100	30-50	5
180x90	50-80	5



**ESEMPI RULLI DI TAGLIO: QUADRO/ EXAMPLES OF CUTTING-ROLLERS: SQUARE-SHAPED**

Lato/Side mm	Peso crudo/Raw weight g	N° tranci/No. of pieces
110X110	50-80	5
130X130	70-100	4
170X170	120-170	3

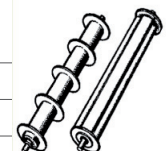



SFOGLIATRICE - STANDARD E LUXE

STANDARD AND DELUXE DOUGH SHEETER

Properties of Esmach SpA - reproduction prohibited

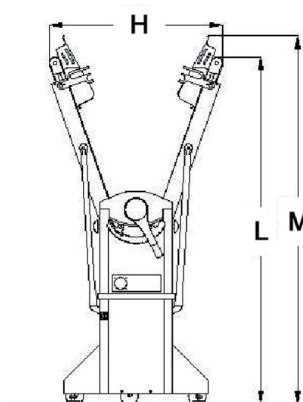
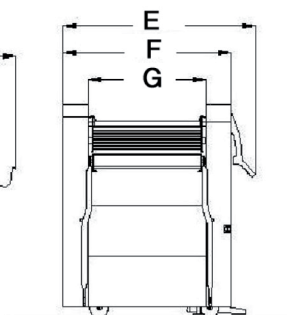
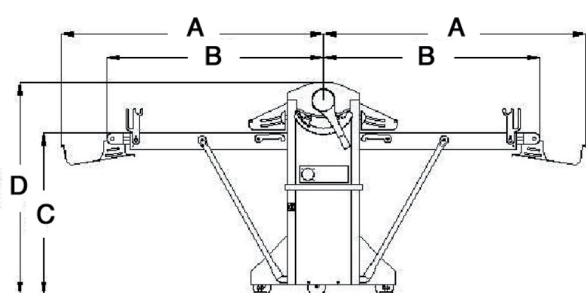
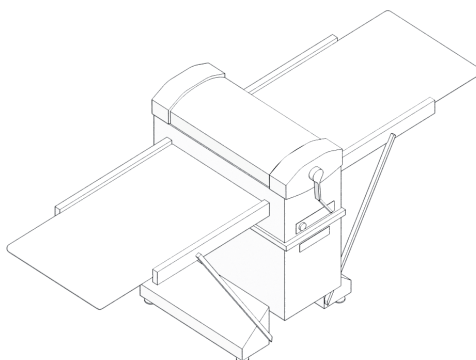

**CARATTERISTICHE TECNICHE - DIMENSIONALI/TECHNICAL FEATURES AND DIMENSIONS**

MODELLI/ MODELS	POTENZA ELETTRICA/ ELECTRIC POWER kW	MASSA/ MASS kg	POSIZIONE LAVORO/WORKING POSITION							IN RIPOSO/REST POSITION		
			Lunghezza/ Length (mm)		Altezza/ Height		Larghezza/ Width			H	L	M
			A	B	C	D	E	F	G			
SFN50-75	0,55	180	1101	848	900	1182	965	830	550	830	1580	1700
SFN50-100	0,55	190	1253	1000						830	1750	1850
SFN50-120	0,55	200	1453	1200						960	1950	2050
SFN60-100	0,75	220	1253	1000	900	1182	1065	930	650	830	1750	1850
SFN60-120	0,75	230	1453	1200						960	1950	2050
SFN60-140	0,75	240	1653	1400						1090	2200	2300
SFN60-160	0,75	250	1853	1600						1230	2300	2400