

1.1 Kw

50/60Hz
400V-3Ph



Macina pane per pane secco o tostato e fresco (kit mollica opzionale). Doppia protezione antinfortunistica. Setaccio con doppia granulometria. Alta produttività. Dimensioni compatte

Bread mill for dry, toasted and fresh bread (optional crumb kit). Double safety guard. Sieve with two grain sizes. High productivity rate. Compact shape

Trituradora de pan para pan seco o tostado y fresco (kit para miga opcional). Protección doble para la prevención de los accidentes. Tamiz con granulometría doble. Alta productividad. Dimensiones compactas

Broyeur de pain pour pain sec ou toasté et frais (kit pour mie en option). Double protection de prévention des accidents. Tamis à double granulométrie. Haute productivité. Dimensions compactes

Оборудование для измельчения сухого или обжаренного, а также свежего хлеба (набор для мякиша дополнительно). Двойная защита безопасности. Сито с двойным грануломером. Высокая продуктивность. Компактные размеры

Semmelbröselmaschine für trockenes oder geröstetes und frisches Brot (Brotkrümel-Set optional). Doppelter Unfallverhütungsschutz. Sieb mit zwei Korngrößen. Hohe Produktivität. Kompakte Abmessungen

	BM11
Setaccio - Sifter	(*)3-4, 5-6, 8-10 mm (mollica/soft bread)
Produzione oraria (pane secco) - Production/h (dry bread)	Fino a 300kg/h / Up to 300kg/h
Sicurezze - Safety	Micro e interblocco / Micro and interlocking system
Sicurezza motore - Motor protection	Pastiglia termica / Thermal protection

(*) fornitura standard / Standard supply

✗ Standard ○ Optional

Specifiche tecniche / Technical specifications



	G42	C42-C52	CP42-CP52	C42S-C52S	CP42S-CP52S	ST42	SA35-SA50	MI52	MR52	MAC100	BM11
Struttura in acciaio verniciata Steel powder painted body	✗	✗	✗	✗	✗	✗	✗	✗	✗		
Modello da tavolo Bench model	✗	✗	✗								
Modello con ruote Models on wheels					✗	✗	✗	✗	✗		
Manuale Manual	✗	✗	✗	✗							
Automatica Automatic			✗		✗	✗	✗	✗	✗		
Automatica a ciclo singolo e continuo Automatic single and continuous mode			✗		✗						
Automatica a ciclo continuo Automatic continuous cut								✗	✗		
Automatica con 4 modalità di taglio Automatic with 4 cutting modes							✗				
Carico frontale Front loading	✗	✗	✗			✗	✗				
Carico laterale/posteriore Lateral/rear loading				✗	✗			✗	✗		
Passo fetta variabile Adjustable pitch							✗				
Telaio coltelli intercambiabile (brevetto) Interchangeable blade cartridge (patent)									✗		
Regolazione elettrica tappeto superiore Electrically adjustable upper conveyor								✗	✗		
Regolazione velocità con inverter Speed regulation with inverter								✗	✗		
Velocità tappeto e telai indipendenti Independent speed of conveyor and cutting frames								✗	✗		
Insufflatore Bag blower				○	○						
Base con ruote Base with wheels	○	○	○								
Oliatore Oiling system	○	○	○	○	○	○	○	○	○		
Struttura in alluminio e inox Aluminum & s/steel structure										✗	✗
Kit mollica Fresh bread knife kit											○
Piedini inox S/steel legs											○



Dimensioni / Dimensions



Peso netto / Net weight

BM11

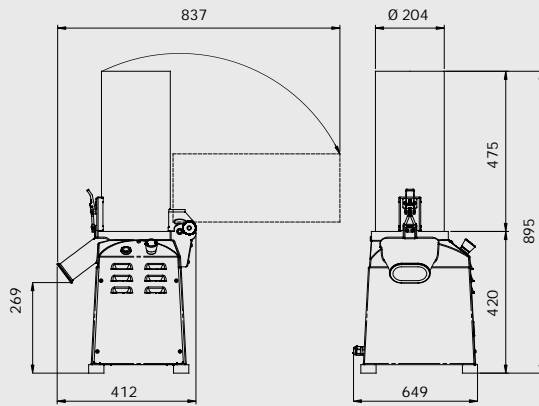

 30 Kg

MAC100

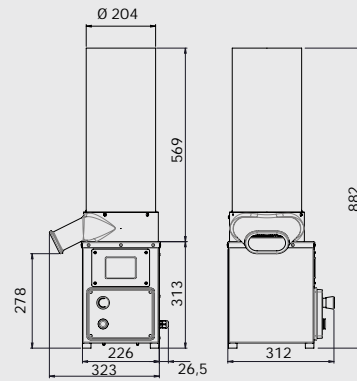

 23 Kg