



EF-P

Properties of Esmach Ali Group S.r.l. - reproduction prohibited



EF-P Electric modular oven

Modular oven with electrical operation that, thanks to the technical characteristics and to the different possible configurations, can be used for baking bread, pastry, pizza and gastronomy products.

Construction

Stackable baking chambers - with independent functioning
 - externally built in stainless steel, with cooking surface in refractory conglomerate and stainless steel hinged door with inspection window. Stainless steel armored electrical resistors.
 Max operating temperature: 400 °C.

Capacity and characteristics of Chambers

They are equipped as standard with steams evacuation valve - they are proposed in three models, with baking surfaces equal to 0,88 sqm - 1,07 sqm - 1,50 sqm corresponding respectively to a capacity of No. 3 - 4 - 6 baking trays mm 400x600. The three versions can be equipped with a useful unloading height of 180 or 250 mm.

Preparations and / or optional

- **Evo-Digital control with power distributor** for the differential management of the powers to the sky and the bottom part with the possibility of working up to 50% of the installed power of the oven, depending on the type of product. ***(available option: left control side to be specified in the order)**
- **Leavening proofer** built in stainless steel, complete with electrical resistors for heating, water tank for humidification and tray-holder grid. Two proofer types are offered, with a height of 580 mm for baking trays mm 400x600 or with a height of 880 mm for tray mm 400x600, to be chosen depending on the final configuration of the set.
- **Automatic steam in proofer**
- **Support stand** as an alternative to the proofer, in stainless steel, with intermediate shelf
- **Natural draft hood**
- **Hood with extractor**
- **Steamer** that can be installed on request, with independent functioning for each baking chamber (when ordering please specify on which chamber it has to be installed).
- **Wheel kit for leavening proofer and supports**

- **Tray-holder kit for supports**
- **Chamber Height H=300mm**
- **Black colored oven**

■ Note:
provide the hydraulic lifter available for the installation.

Configuration	2TS	2TL	3TL	4TS	4TL	6TL	8TL
Controls							
Oven Right side	■	■	■	■	■	■	■
Oven Left side	□ €	□ €	□ €	□ €	□ €	□ €	□ €
Evo-Digital Control with power distributor	■	■	■	■	■	■	■
Elements							
Decorative band	□ €	□ €	□ €	□ €	□ €	□ €	□ €
Natural draft hood	□ €	□ €	□ €	□ €	□ €	□ €	□ €
Hood with extractor	□ €	□ €	□ €	□ €	□ €	□ €	□ €
Leavening proofer	□ €	□ €	□ €	□ €	□ €	□ €	□ €
Automatic steam in the leavening proofer	□ €	□ €	□ €	□ €	□ €	□ €	□ €
Support Stand	□ €	□ €	□ €	□ €	□ €	□ €	□ €
Tray-holder kit	□ €	□ €	□ €	□ €	□ €	□ €	□ €
Wheels kit	□ €	□ €	□ €	□ €	□ €	□ €	□ €
Chamber Steam generator	□ €	□ €	□ €	□ €	□ €	□ €	□ €
Chamber Height H=300 mm	□ €	□ €	□ €	□ €	□ €	□ €	□ €
Black colored oven	□ €	□ €	□ €	□ €	□ €	□ €	□ €
Supply Voltage							
400 TRI + N + T 50Hz	■	■	■	■	■	■	■
■ Standard □ € Payment option ND Not available							



EF-P - 2TS

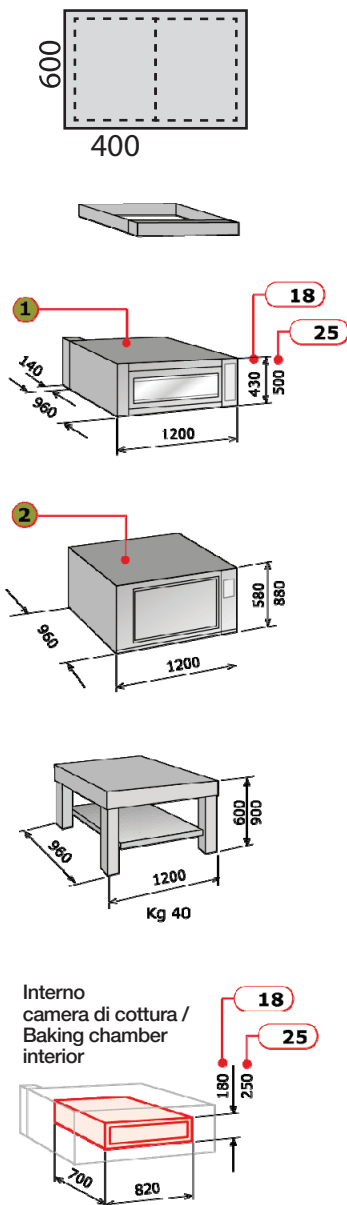

2 Baking pans 4060 Pastry	Chamber h 180	EF-P AS 180-2TS 400/3/50
	Chamber h 250	EF-P AS 250-2TS 400/3/50
	Option: sheet metal top - per chamber	OPT SHEET METAL

2 Baking pans 4060 Bread	Chamber h 180	EF-P ZZ 180-2TS 400/3/50
	Chamber h 250	EF-P ZZ 250-2TS 400/3/50
	Standard steam generator - per chamber	EF-P STEAM GENERATOR 1.5 kw

2 Baking pans 4060 Pizza	Chamber h 180	EF-P ZZ 180-2TS 400/3/50
	Chamber h 250	EF-P ZZ 250-2TS 400/3/50
	Option: refractory stone top	OPT 2T REFRACTORY STONE TOP

Option to complement 2TS 4060	Option: leavening proofer	EF-P 2TS 400/3/50 PROOFER
	Supporting stand	EF-P 2T STAND
	Extraction hood with manual draught	TN EF-P 2T HOOD
	Hood with extractor	EF-P 2T 400/3/50 EXTRACTOR HOOD
	Decorative band	OPT 2TS BAND
	Kit of wheels	EF-P WHEEL KIT
	Kit of tray-holders	EF-P TRAY-HOLDER KIT
	Option: black oven - per chamber	OPT EF-P 2T 400/3/50 BLACK

Connection socket, without steam generator: 16 A
 Connection socket, with steam generator: 32 A

Ø Steam evacuation pipe:
 - Ø 120 without hood extractor
 - Ø 140 with extractor

	Model EF-P 2TS	No. of oven chambers	Pans No.	Power kW	Power distributor kW	Mass kg
1	AS180		2	6,6	3,3	160 kg standard, 200 kg with steam generator
	AS 250					
	ZZ180					
	ZZ 250					
2	Leavening proofer*	2	16	1,6		85
		3	10			

* For ovens with more than three rooms please ask to Sales Dept.



EF-P - 2TL

Properties of Esmach Ali Group S.r.l. - reproduction prohibited

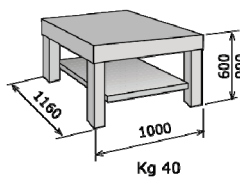
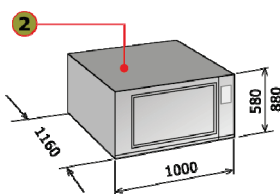
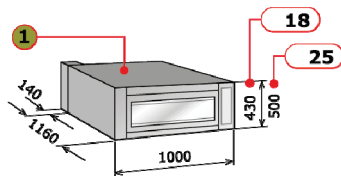
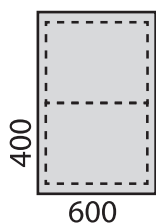

Interno camera di cottura / Baking chamber interior

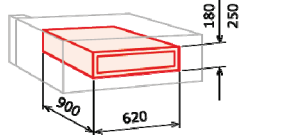

2 Baking pans 6040 Pastry	Chamber h 180	EF-P AS 180-2TL 400/3/50
	Chamber h 250	EF-P AS 250-2TL 400/3/50
	Option: sheet metal top - per chamber	OPT SHEET METAL

2 Baking pans 6040 Bread	Chamber h 180	EF-P ZZ 180-2TL 400/3/50
	Chamber h 250	EF-P ZZ 250-2TL 400/3/50 1.5 kw
	Standard steam generator - per chamber	EF-P STEAM GENERATOR

2 Baking pans 6040 Pizza	Chamber h 180	EF-P ZZ 180-2TL 400/3/50
	Chamber h 250	EF-P ZZ 250-2TL 400/3/50
	Option: refractory stone top	OPT 2T REFRACTORY STONE TOP

Option to complement 2TL 6040	Option: leavening proofer	EF-P 2TL 400/3/50 PROOFER
	Supporting stand	EF-P 2T STAND
	Extraction hood with manual draught	TN EF-P 2T HOOD
	Hood with extractor	EF-P 2T 400/3/50 EXTRACTOR HOOD
	Decorative band	OPT 2TL BAND
	Kit of wheels	EF-P WHEEL KIT
	Kit of tray-holders	EF-P TRAY-HOLDER KIT
	Option: black oven - per chamber	OPT EF-P 2T 400/3/50 BLACK

Connection socket, without steam generator: 16 A
Connection socket, with steam generator: 32 A

Ø Steam evacuation pipe:
- Ø 120 without hood extractor
- Ø 140 with extractor

	Modello EF-P 2TL	No. of oven chambers	Pans No.	Power kW	Power distributor kW	Mass kg
1	AS180		2	6	3	160 kg standard, 200 kg with steam generator
	AS 250					
	ZZ180					
	ZZ 250					
2	Leavening proofer*	2	16	1,6		85
		3	10			

* For ovens with more than three rooms please ask to Sales Dept.



EF-P - 3T

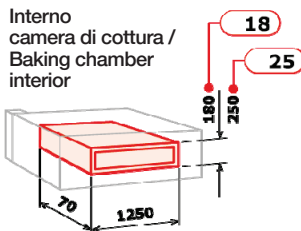
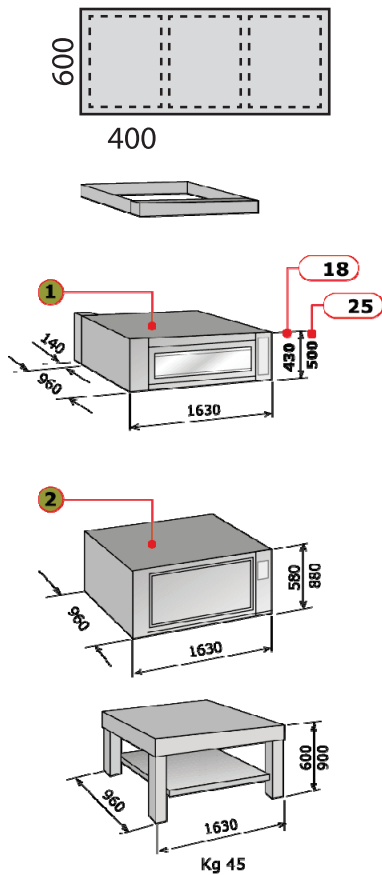

3 Baking pans 4060 Pastry	Chamber h 180	EF-P AS 180-3T 400/3/50
	Chamber h 250	EF-P AS 250-3T 400/3/50
	Option: sheet metal top - per chamber	OPT SHEET METAL

3 Baking pans 4060 Bread	Chamber h 180	EF-P ZZ 180-3T 400/3/50
	Chamber h 250	EF-P ZZ 250-3T 400/3/50
	Standard steam generator - per chamber	EF-P STEAM GENERATOR 1.5kw

3 Baking pans 4060 Pizza	Chamber h 180	EF-P ZZ 180-3T 400/3/50
	Chamber h 250	EF-P ZZ 250-3T 400/3/50
	Option: refractory stone top	OPT 3T REFRACTORY STONE TOP

Option to complement 3T 4060	Option: leavening proofer	EF-P 3T 400/3/50 PROOFER
	Supporting stand	EF-P 3T STAND
	Extraction hood with manual draught	TN EF-P 3T HOOD
	Hood with extractor	EF-P 3T 400/3/50 EXTRACTOR HOOD
	Decorative band	OPT 3T BAND
	Kit of wheels	EF-P WHEEL KIT
	Kit of tray-holders	EF-P TRAY-HOLDER KIT
	Option: black oven - per chamber	OPT EF-P 3T 400/3/50 BLACK

Connection socket, without steam generator: 16 A
 Connection socket, with steam generator: 32 A

Ø Steam evacuation pipe:
 - Ø 120 without hood extractor
 - Ø 180 with extractor

	Model EFP 3T	No. of oven chambers	Baking pans No.	Power kW	Power distributor kW	Mass kg
1	AS180		3	8,4	4,2	230 kg standard, 200 kg with steam generator
	AS 250					
	ZZ180					
	ZZ 250					
2	Leavening proofer*	2	32	1,6		120
		3	20			

* For ovens with more than three rooms please ask to Sales Dept.



EF-P - 4TS

Properties of Esmach Ali Group S.r.l. - reproduction prohibited

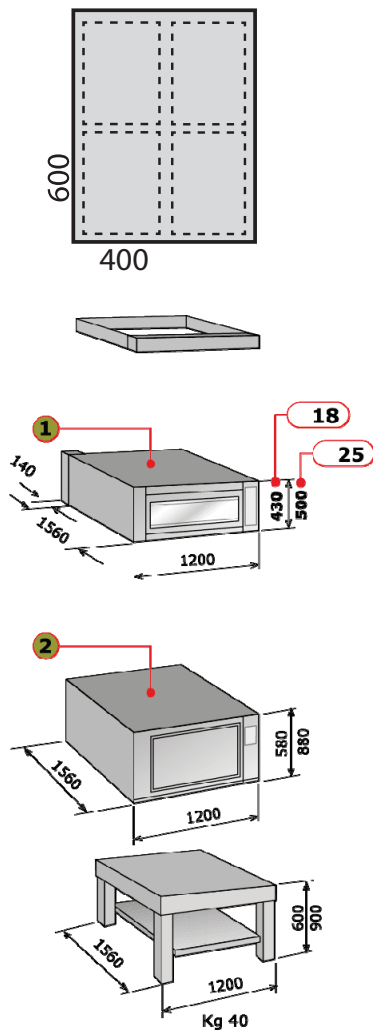

4 Baking pans 4060 Pastry	Chamber h 180	EF-P AS 180-4TS 400/3/50
	Chamber h 250	EF-P AS 250-4TS 400/3/50
	Option: sheet metal top - per chamber	OPT SHEET METAL

4 Baking pans 4060 Bread	Chamber h 180	EF-P ZZ 180-4TS 400/3/50
	Chamber h 250	EF-P ZZ 250-4TS 400/3/50
	Standard steam generator - per chamber	EF-P STEAM GENERATOR 1,5 kw

4 Baking pans 4060 Pizza	Chamber h 180	EF-P ZZ 180-4TS 400/3/50
	Chamber h 250	EF-P ZZ 250-4TS 400/3/50
	Option: refractory stone top	OPT 4T REFRACTORY STONE TOP

Option to complement 4TS 4060	Option: leavening proofer	EF-P 4TS 400/3/50 PROOFER
	Supporting stand	EF-P 4T STAND
	Extraction hood with manual draught	TN EF-P 4T HOOD
	Hood with extractor	EF-P 4T 400/3/50 EXTRACTOR HOOD
	Decorative band	OPT 4TS BAND
	Kit of wheels	EF-P WHEEL KIT
	Kit of tray-holders	EF-P TRAY-HOLDER KIT
	Option: black oven - per chamber	OPT EF-P 4T 400/3/50 BLACK

Connection socket, without steam generator: 16 A
Connection socket, with steam generator: 32 A

Ø Steam evacuation pipe:
- Ø 120 without hood extractor
- Ø 180 with extractor

Model EF-P 4TS	No. of oven chambers	Baking pans No.	Power kW	Power distributor kW	Mass kg
AS180		4	8,4	4,2	240 kg standard, 200 kg with steam generator
AS 250					
ZZ180			11,7	5,85	
ZZ 250					
Leavening proofer*	2	24	1,6		120
	3	15			

* For ovens with more than three chambers, please ask our Sales Dept.



EF-P - 4TL

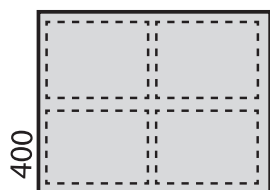

600

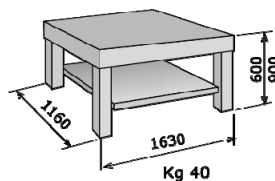
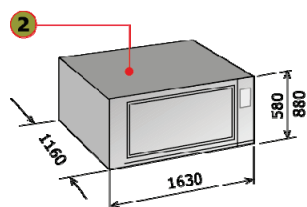
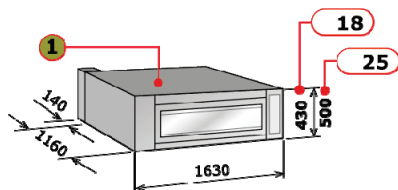

Kg 40

Interno camera di cottura /
Baking chamber interior

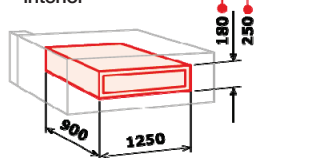

4 Baking pans 6040 Pastry	Chamber h 180	EF-P AS 180-4TL 400/3/50
	Chamber h 250	EF-P AS 250-4TL 400/3/50
	Option: sheet metal top - per chamber	OPT SHEET METAL

4 Baking pans 6040 Bread	Chamber h 180	EF-P ZZ 180-4TL 400/3/50
	Chamber h 250	EF-P ZZ 250-4TL 400/3/50
	Standard steam generator - per chamber	EF-P STEAM GENERATOR 1,5 kw

4 Baking pans 6040 Pizza	Chamber h 180	EF-P ZZ 180-4TL 400/3/50
	Chamber h 250	EF-P ZZ 250-4TL 400/3/50
	Option: refractory stone top	OPT 4T REFRACTORY STONE TOP

Option to complement 4TL 6040	Option: leavening proofer	EF-P 4TL 400/3/50 PROOFER
	Supporting stand	EF-P 4T STAND
	Extraction hood with manual draught	TN EF-P 4T HOOD
	Hood with extractor	EF-P 4T 400/3/50 EXTRACTOR HOOD
	Decorative band	OPT 4TL BAND
	Kit of wheels	EF-P WHEEL KIT
	Kit of tray-holders	EF-P TRAY-HOLDER KIT
	Option: black oven - per chamber	OPT EF-P 4T 400/3/50 BLACK

Connection socket, without steam generator: 16 A
Connection socket, with steam generator: 32 A

Ø Steam evacuation pipe:
- Ø 120 without hood extractor
- Ø 180 with extractor

	Model EF-P 4TL	No. of oven chambers	Baking pans No.	Power kW	Power distributor kW	Mass kg
1	AS180		4	11,2	5,6	260 kg standard, 300 kg with steam generator
	AS 250					
	ZZ180			12,8	6,4	
	ZZ 250					
2	Leavening proofer*	2	32	1,6		120
		3	20			

* For ovens with more than three chambers, please ask our Sales Dept.



EF-P - 6TL

Properties of Esmach Ali Group S.r.l. - reproduction prohibited

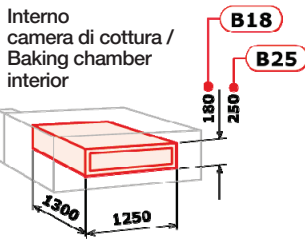
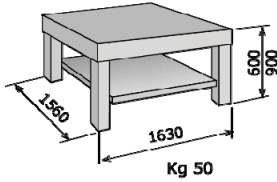
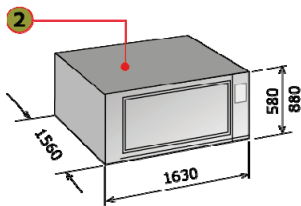
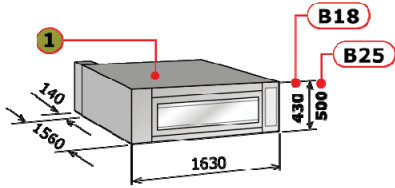
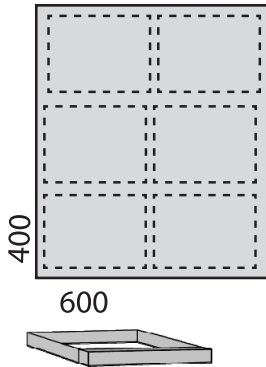

6 Baking pans 6040 Pastry	Chamber h 180	EF-P AS 180-6TL 400/3/50
	Chamber h 250	EF-P AS 250-6TL 400/3/50
	Option: sheet metal top - per chamber	OPT SHEET METAL

6 Baking pans 6040 Bread	Chamber h 180	EF-P ZZ 180-6TL 400/3/50
	Chamber h 250	EF-P ZZ 250-6TL 400/3/50
	Standard steam generator - per chamber	EF-P STEAM GENERATOR
	Enhanced steam generator - per chamber	ENHANCED STEAM GENERATOR 2,3 kw

6 Baking pans 6040 Pizza	Chamber h 180	EF-P ZZ 180-6TL 400/3/50
	Chamber h 250	EF-P ZZ 250-6TL 400/3/50
	Option: refractory stone top	OPT 6TL REFRACTORY STONE TOP

Option to complement 6TL 6040	Option: leavening proofer	EF-P 6TL 400/3/50 PROOFER
	Supporting stand	EF-P 6TL STAND
	Extraction hood with manual draught	TN EF-P 6TL HOOD
	Hood with extractor	EF-P 6TL 400/3/50 EXTRACTOR HOOD
	Decorative band	OPT 6TL BAND
	Kit of wheels	EF-P WHEEL KIT
	Kit of tray-holders	EF-P TRAY-HOLDER KIT
	Option: black oven - per chamber	OPT EF-P 6TL 400/3/50 BLACK

Connection socket, without steam generator: 16 A
 Connection socket, with steam generator: 32 A

Ø Steam evacuation pipe:
 - Ø 120 without hood extractor
 - Ø 180 with extractor

	Model EF-P 6TL	No. of oven chambers	Baking pans No.	Power kW	Power distributor kW	Mass kg
1	AS180		4	15	7,5	340 kg standard, 380 kg with steam generator, 410 kg with steam generator
	AS 250					
	ZZ180			16,4		
	ZZ 250					
2	Leavening proofer*	2	48	1,6		200
		3	30			

* For ovens with more than three chambers, please ask our Sales Dept.



EF-P - 8TL

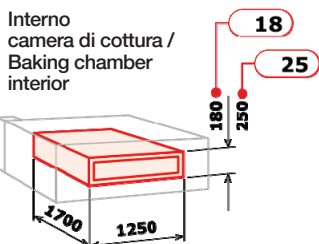
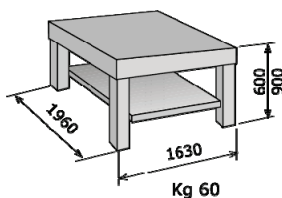
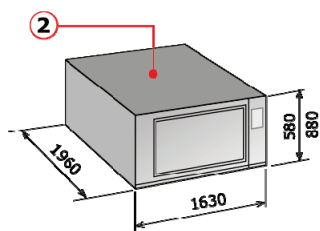
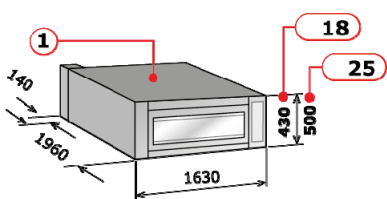
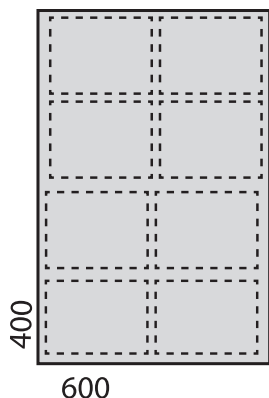

8 Baking pans 6040 Pastry	Chamber h 180	EF-P AS 180-8TL 400/3/50
	Chamber h 250	EF-P AS 250-8TL 400/3/50
	Option: sheet metal top - per chamber	OPT SHEET METAL

8 Baking pans 6040 Bread	Chamber h 180	EF-P ZZ 180-8TL 400/3/50
	Chamber h 250	EF-P ZZ 250-8TL 400/3/50
	Standard steam generator - per chamber	EF-P STEAM GENERATOR
	Enhanced steam generator - per chamber	ENHANCED STEAM GENERATOR 2,3 kw

8 Baking pans 6040 Pizza	Chamber h 180	EF-P ZZ 180-8TL 400/3/50
	Chamber h 250	EF-P ZZ 250-8TL 400/3/50
	Option: refractory stone top	OPT 8TL REFRACTORY STONE TOP

Option to complement 8TL 6040	Option: leavening proofer	EF-P 8TL 400/3/50 PROOFER
	Supporting stand	EF-P 8TL STAND
	Extraction hood with manual draught	TN EF-P 8TL HOOD
	Hood with extractor	EF-P 8TL 400/3/50 EXTRACTOR HOOD
	Decorative band	OPT 8TL BAND
	Kit of wheels	EF-P WHEEL KIT
	Kit of tray-holders	EF-P TRAY-HOLDER KIT
	Option: black oven - per chamber	OPT EF-P 8TL 400/3/50 BLACK

Connection socket, without steam generator: 16 A
 Connection socket, with steam generator: 32 A

- Ø Steam evacuation pipe:
- Ø 120 without hood extractor
 - Ø 180 with extractor

	Model EF-P 8TL	No. of oven chambers	Baking pans No.	Power kW	Power distributor kW	Mass kg
1	AS180		4	16,4	8,2	440 kg standard, 480 kg with steam generator, 510 kg with steam generator
	AS 250					
	ZZ180					
	ZZ 250					
2	Leavening proofer*	2	48	1,6		230
		3	30			

* For ovens with more than three chambers, please ask our Sales Dept.