



SPI F



according
to EN 453
standard rev.
2015

Spiral mixer with fixed bowl

Our new SPI range of spiral mixers is the outcome of our culture and know-how in quality processing of all kinds of dough kneading for bakeries, pizzerias and confectionery industries as well as our meticulous research in H4product technology. Structural strength, extraordinary versatility of use, reliability, high standard of safety features, accuracy in the manufacturing process, ergonomics and attractive design highlight our proven success in dough making and project our tradition onto the future.

SPI is available in 10 models with a dough capacity ranging from 30 kg to 300 kg. This is our cutting-edge range of spiral mixers, the line of which is simple and modern. An electro-mechanical or an electronic version of SPI spiral mixer is also available.

Esmach has focused the attention not only on researching and monitoring successfully all aspects regarding the process and dough rising, the latest products, the rheological properties of the mixtures, their timing and their final temperature but also on versatility of use with optimum results while processing both minimum and maximum capacity of dough to be achieved.

Standard features

- Steel frame properly enlarged and strengthened to confer firm stability to the machine structure even during the most demanding processes and to transfer entirely the mechanical energy, developed by the tool, to the dough kneading,
- Outer paneling painted with an anticorrosion double epoxy powder coating and suitable for food contact.
- Stability and levelling on the floor assured by three casters with blocking wedges useful for handling the machine while cleaning it deeply in the area underneath the frame.
- Stainless steel bowl with stainless steel rim for extra support, dividing blade and spiral arm.
- Transparent bowl lid suitable for food contact in compliance with the strictest hygienic and safety regulations.
- Innovative flat cover top in scratch-resistant ABS, divided in two sections.
- Electric panel in an IP55 protection box against flour dust and water sprays.
- Direct power transmission for the rotation of both spiral arm and bowl generated by trapezoidal drive belts on multi-groove pulleys.
- Independent motors for bowl and spiral arm in the models from 60 to 300 kg. An only one motor for 30 and 45 kg models. Two working speeds for bowl and spiral arm. Reversal of bowl rotation at first speed (except 30 and 45 kg models).
- Functional and innovative command console with rotation in both left and right directions and with an operative angle of 120°, allowing ideal ergonomic comfort also in narrow working rooms.
- Manual or automatic selection and monitoring of working cycle through a membrane keyboard panel in the electronic version only. Storage of up to 9 recipes.

- Power supply: 400V/3/50 Hz (different voltage upon request)

Plus

- Optimum balance between bowl rotation and spiral arm enabling a right kneading flow and a soft and gentle dough kneading.
- Perfectly shaped spiral arm rotation inside the bowl and right accurate proportions among bowl, spiral arm and dividing blade well matched together to get homogeneous, soft and distinguished dough also while using small dough amounts.
- Accurate bowl and spiral arm speed for an excellent dough kneading and its processing through stretching and lengthening, allowing continuous and constant dough kneading with a significant reduction of the processing time and limited heating up of the dough.

Accessories - optional

- Small trolley suitable for spiral mixer handling;
- The electronic version of the model can be supplied with the following accessories:
 - Lid + grid: stainless steel grid in addition to the transparent lid;
 - Water dispenser directly on the bowl with liter meter, mixer for manual temperature and temperature sensor on display.
- Dough temperature detector with infrared sensor, visualization on display and stop option of the working process or immersion temperature detector with external sensor connected to the circuit board.



MODELS

SPI 30 F E	Spiral mixer with approx. kg. 30 dough capacity (approx. kg. 18-20 flour capacity). Bowl diameter: 450 mm. Electromechanical control panel.
SPI 30 F M	Spiral mixer with approx. kg. 30 dough capacity (approx. kg. 18-20 flour capacity). Bowl diameter: 450 mm. Electromechanical control panel.
SPI 45 F E	Spiral mixer with approx. kg. 45 dough capacity (approx. kg. 30 flour capacity). Bowl diameter: 530 mm. Electromechanical control panel.
SPI 45 F M	Spiral mixer with approx. kg. 45 dough capacity (approx. kg. 30 flour capacity). Bowl diameter: 530 mm. Electromechanical control panel.
SPI 60 F E	Spiral mixer with approx. kg. 60 dough capacity (approx. kg. 40 flour capacity). Bowl diameter: 550 mm. Electromechanical control panel.
SPI 60 F M	Spiral mixer with approx. kg. 60 dough capacity (approx. kg. 40 flour capacity). Bowl diameter: 550 mm. Electromechanical control panel.
SPI 80 F E	Spiral mixer with approx. kg. 80 dough capacity (approx. kg. 50-54 flour capacity). Bowl diameter: 700 mm. Electromechanical control panel.
SPI 80 F M	Spiral mixer with approx. kg. 80 dough capacity (approx. kg. 50-54 flour capacity). Bowl diameter: 700 mm. Electromechanical control panel.
SPI 100 F E	Spiral mixer with approx. kg. 100 dough capacity (approx. kg. 62-65 flour capacity). Bowl diameter: 700 mm. Electromechanical control panel.
SPI 100 F M	Spiral mixer with approx. kg. 100 dough capacity (approx. kg. 62-65 flour capacity). Bowl diameter: 700 mm. Electromechanical control panel.
SPI 130 F E	Spiral mixer with approx. kg. 130 dough capacity (approx. kg. 75-80 flour capacity). Bowl diameter: 800 mm. Electromechanical control panel.
SPI 130 F M	Spiral mixer with approx. kg. 130 dough capacity (approx. kg. 75-80 flour capacity). Bowl diameter: 800 mm. Electromechanical control panel.
SPI 160 F E	Spiral mixer with approx. kg. 160 dough capacity (approx. kg. 100 flour capacity). Bowl diameter: 900 mm. Electromechanical control panel.
SPI 160 F M	Spiral mixer with approx. kg. 160 dough capacity (approx. kg. 100 flour capacity). Bowl diameter: 900 mm. Electromechanical control panel.
SPI 200 F E	Spiral mixer with approx. kg. 200 dough capacity (approx. kg. 125 flour capacity). Bowl diameter: 900 mm. Electromechanical control panel.
SPI 200 F M	Spiral mixer with approx. kg. 200 dough capacity (approx. kg. 125 flour capacity). Bowl diameter: 900 mm. Electromechanical control panel.
SPI 250 F E	Spiral mixer with approx. kg. 250 dough capacity (approx. kg. 150 flour capacity). Bowl diameter: 1045 mm. Electromechanical control panel.
SPI 300 F E	Spiral mixer with approx. kg. 300 dough capacity (approx. kg. 200 flour capacity). Bowl diameter: 1045 mm. Electromechanical control panel.

ACCESSORIES - OPTION

	Small trolley suitable for spiral mixer handling
	Lid + grid: stainless steel grid in addition to the transparent lid (available for electronic version only)
	Water dispenser directly on the bowl with liter counter, mixer for manual temperature, temperature sensor on display (available for electronic version only)
	Dough temperature detector with infrared sensor, visualization on display and stop option of the working process (available for electronic version only)
	Immersion temperature detector with external sensor connected to the circuit board (available for electronic version only)



Option: LID + GRID



Spiral mixer with fixed bowl SPI F

DATI TECNICI / TECHNICAL DATA		SPI 30F	SPI 45F	SPI 60F	SPI 80F	SPI 100F	SPI 130F	SPI 160F	SPI 200F	SPI 250F	SPI 300F	
A	mm	477	477	565	588	588	735	735	735	735	735	
B	mm	978	978	1150	1207	1207	1413	1495	1495	1640	1640	
C	mm	1378	1378	1530	1563	1563	1610	1610	1610	1719	1719	
D	mm	741	791	911	886	936	862	883	943	932	1009	
E	mm	1879	1864	1705	1751	1776	1864	1945	1975	2144	2182	
F	mm	562	562	675	741	741	847	948	948	1069	1069	
G	mm	181	131	153	189	139	222	202	142	219	142	
Massa macchina / Machine mass	kg	218	222	360	417	417	624	680	705	843	850	
Massa con solo pallet / Mass with pallet only	kg	239	243	395	452	452	660	716	741	893	900	
Massa con gabbia / Mass with crate	kg	301	305	479	536	536	744	800	825	968	975	
Massa con cassa / Mass with case	kg	323	327	556	613	613	765	821	846	1038	1045	
Dimensioni esterne (macchina su pallet) / Overall dimensions (machine on pallet)	mm	1150x650x1550			1300x850x1730			1600x1000x1750			1800x1250x1930	
Dimensioni esterne Imballo (gabbia/cassa) / Overall packing dimensions (crate/case)	mm	1250x750x1670			1400x950x1820			1700x1100x1850			1900x1350x2030	
Capacità impasto minima/massima (a) / Min - max dough capacity (a)	kg	2/30	2.5/45	3/60	3.5/80	4/100	4/130	4.5/160	4.5/200	10/250	10/300	
Capacità vasca / Bowl capacity	L	50	60	95	120	145	200	250	290	360	430	
1a/2a Velocità rot. Spirale / 1st/2nd Spiral arm rotation speed	r.p.m.	103/206				107/214				97-194		
1a/2a Velocità rot. Vasca / 1st/2nd Bowl rotation speed	r.p.m.	10/20		7.5/15	8/16		10.8/21.6			10/20		
Potenza installata / Installed power	kW	1.5	1.5	2.57	4.55	4.55	6.8	8.4	8.4	11,8	11,8	
Potenza motore spirale / Spiral arm motor power	kW	1.5-0.75 (b)		2.2 - 1.5	4 - 3	4 - 3	5.9 - 4.05	7.5 - 4.8	7.5 - 4.8	10,3-7	10,3-7	
Potenza motore vasca / Bowl motor power	kW	-	-	0.55-0.37	0.55-0.37	0.55-0.37	0.9-0.45	0.9-0.45	0.9-0.45	1,5-0,75	1,5-0,75	
Tensione (c) / Voltage (c)	V	400										
Frequenza (c) / Frequency (c)	Hz	50										
Numero fasi (c) / No. of phases (c)	-	3 Ph + Gr										

(a) the max. mixture capacity shown refers to a water/flour ratio not less than 60% (flour W= 250, P/L= 0,4); it reduces in the ratio decrease:(water quantity)/(flour quantity)

(b) same motor both for spiral arm and bowl

(c) these values represent the most frequent case; should voltage and/or frequency and/or no. of phases be different, the specifications shown on the identification plate will be valid only.



Electronic control panel for SPI



Electromechanical control panel for SPI



Small trolley for SPI F handling



IMPASTATRICE A SPIRALE SPI F

NOR12A001

SPIRAL MIXER SPI F

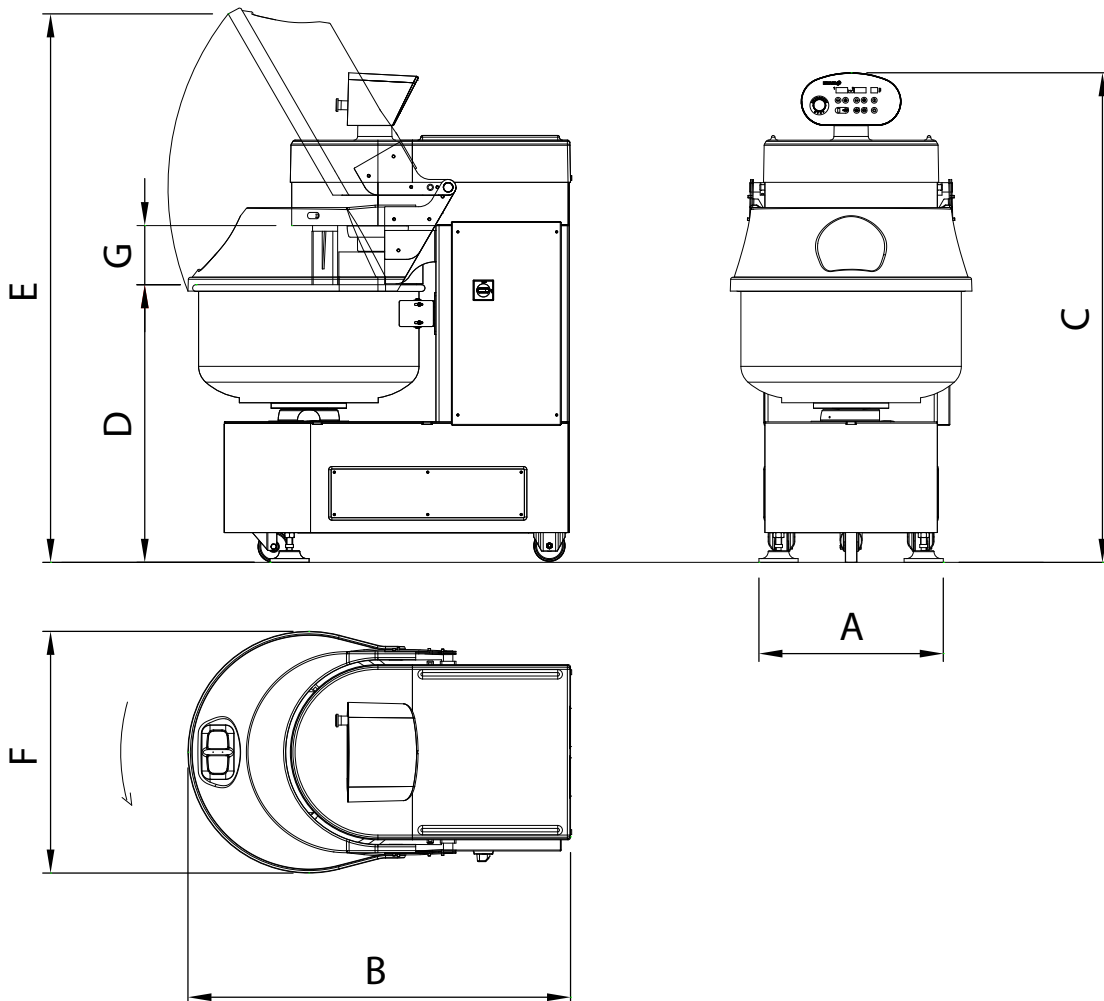
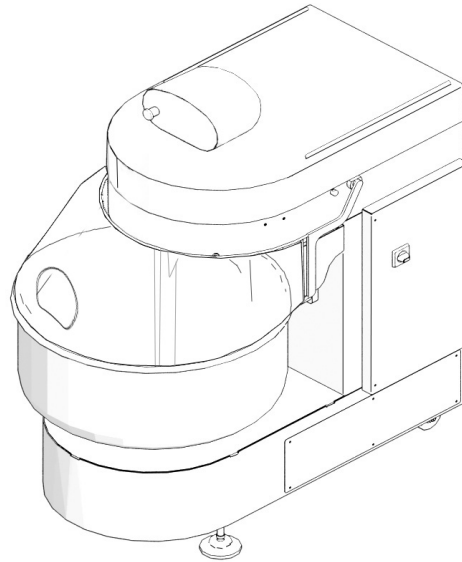



NOR14A001_01

SPI F - ALLACCIAMENTO IDRAULICO (solo per macchine dotate di sistema di dosaggio acqua)

SPI F - HYDRAULIC CONNECTION (for machine equipped with water dispenser system only)

Properties of Esmach SpA - reproduction prohibited

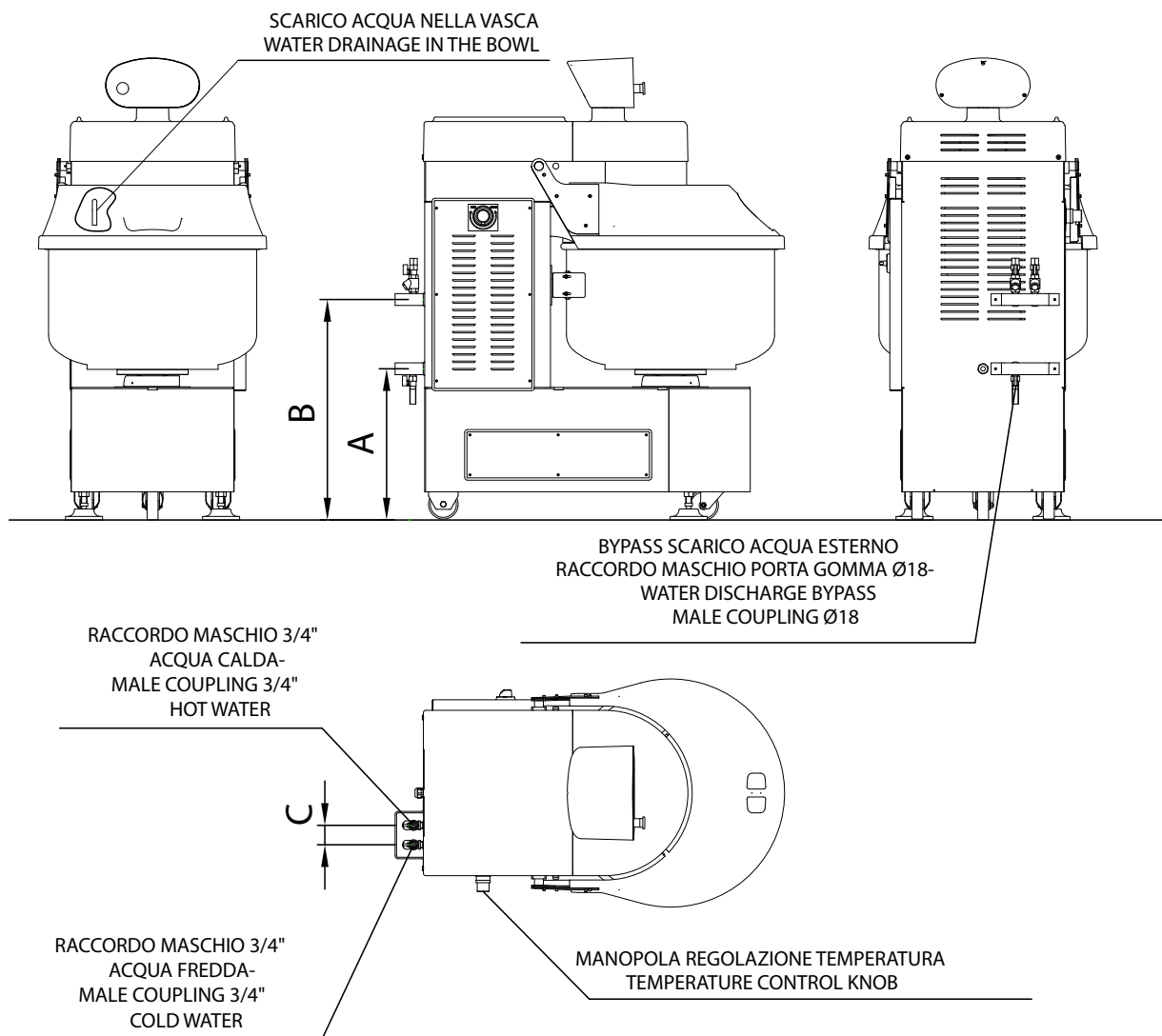

** l'impianto viene fornito con due tubi flessibili l=1.5 m f-f 3/4" per l'ingresso acqua e un tubo flessibile l=1.5 m diametro 18 per lo scarico bypass
 ** the water dispenser includes 2 exible tubes l=1.5 m f-f 3/4" for the water input and a exible tube l=1.5 m 18 diameter fot the discharge bypass

DATI TECNICI SPI F		30 / 45	60 / 80 / 100	130 / 160 / 200	250 / 300
SPI F TECHNICAL FEATURES					
A	mm	510	511	313	430
B	mm	570	745	805	664
C	mm	66	66	66	66